

CFW Coolant and Fuel/Oil Heating System

The Hotstart® CFW is a complete pre-heater with a heating chamber for coolant, a pump and all required controls. Depending on additional liquid heating needs, a separate heat exchanger heats either fuel or lube oil. The CFW heats engines ranging in size from 40L to 150L displacement. Forced circulation of coolant and fuel (or oil) delivers uniform heating throughout the entire engine, extends element life and reduces electrical consumption.

Application:

The CFW was developed to preheat diesel and gas engines for stationary land power, marine, rail, large mining and construction equipment.



Specifications:

- Heating Fluid: Coolant and Fuel, or Oil
- Power: 12, 18 and 24kW
- Rated Voltage: 1 or 3 Phase (208V – 575V)
50Hz or 60Hz
- Tank Material: Steel (coolant)
- SST (heat exchanger)
- Thermostat: 100° - 120°F (38° - 48°C)
- Ingress Protection: NEMA 2
- Fluid Capacity: 0.925 gl Coolant (3.5L)
0.26 gl Oil or Fuel (1L)
- Pump Power: 0.16 hp (0.122 kW) coolant
1 hp (0.75 kW) oil
- Coolant Flow: 15 GPM (3.4 m³/hr) @
15ft head (.45 bar)
- Flow Switch: 2 GPM (0.45 m³/hr)
- Max Pressure: 125PSI (8.61 bar) coolant & oil
- Pressure Loss: 3PSI (0.20 bar) coolant & oil
- Pressure Relief Valve: 90PSI (6.2 bar) coolant
- 1" NPT Inlets, #16 JIC Outlets

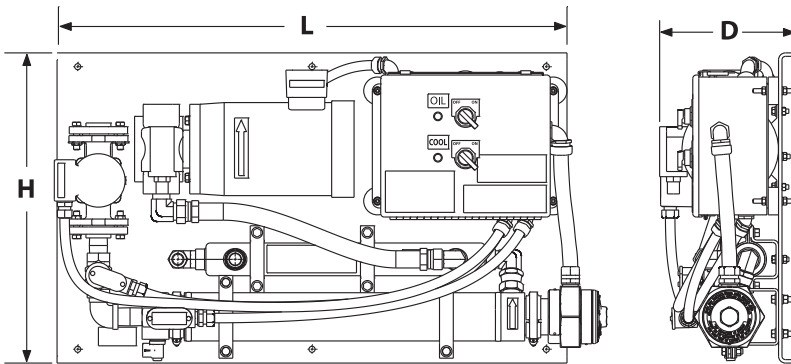

Dimensions & Weight

Phase		1Ø or 3Ø
Height (H)	mm (In)	572 (22.5)
Length (L)	mm (In)	1018 (40.0)
Depth (D)	mm (In)	251 (9.88)
Weight	kg (lbs)	110 (242.5)

Features:

- Optional oil thermostat
- 24VDC relay for auto ON/OFF
- Flow switch for increased protection
- Optional 3-Way switch for local and remote operation



www.kimhotstart.com

ISO 9001:2000